

F

U

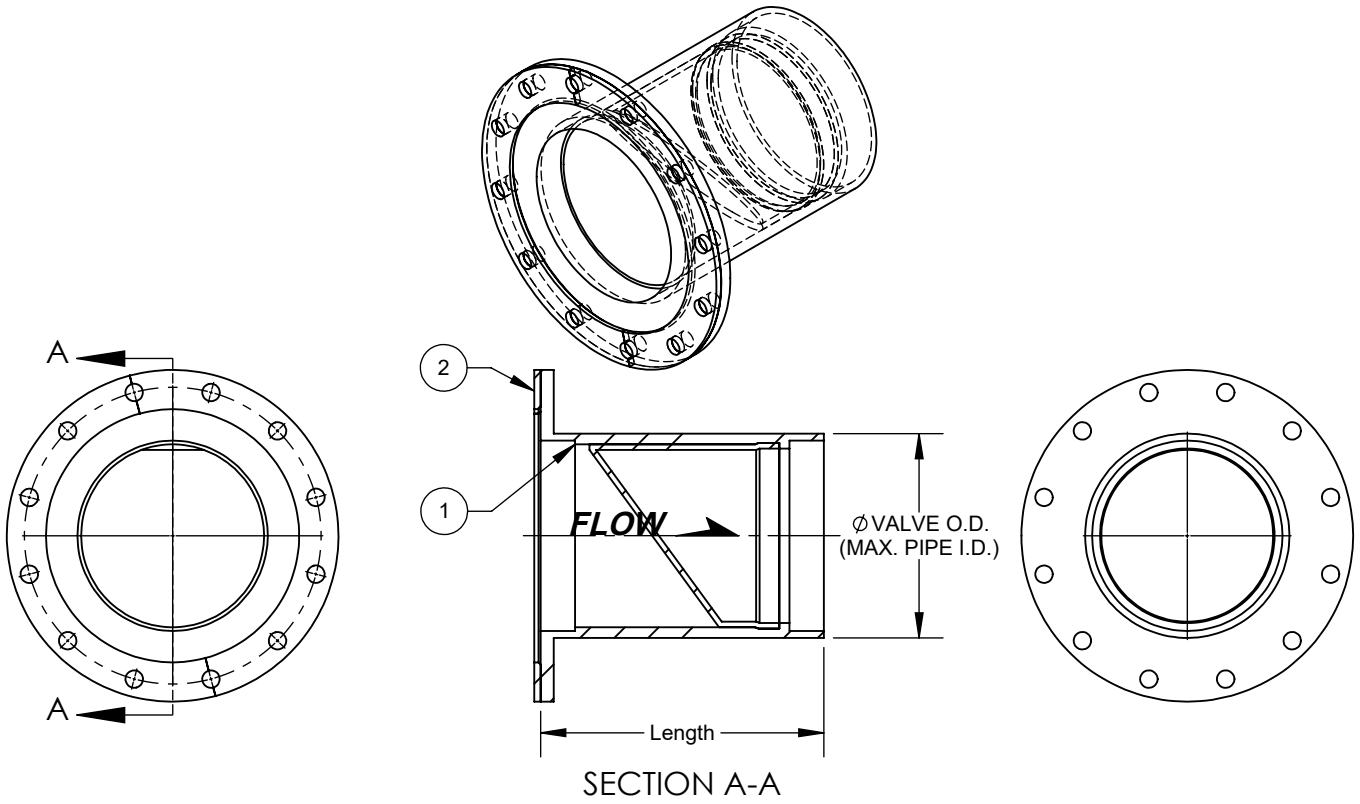

Bill of Materials

Item No.	Description	Material
1	CheckFlex CF-ILIF-G5: In-Line Check Valve	DDB (EE, NN, NSF, PP, NR, VV)
2	Encapsulated Retaining Ring	DDB (304SS, 316SS, Not Required)

1. Dimensions are approximate and may change due to pipe dimension, inlet pressure, back pressure and flow rates.
2. Retaining rings available if installed directly to mating flange. If installed between two mating flanges retaining rings not required.
3. Installation, Operation & Maintenance Manuals contact measurit: info@measurit.com

Nominal Diameter	Qty.	Pipe I.D.	Flange Position	Flange Drilling	Flow Data				
					Flow Media	Max. Flow Rate	Max. Flow Velocity	Line Pressure	Back Pressure
			INLET END	DDB(150#, 300#, DIN10/16)					

Elastomer Material Code	Cover Elastomer	Tube Elastomer	Maximum Operating Temperature
			°F (°C)
EE	EPDM	EPDM	250 (121)
NN	NEOPRENE	NEOPRENE	225 (107)
NN-NSF61	ANSI/NSF 61 NEOPRENE	ANSI/NSF 61 NEOPRENE	225 (107)
PP	NITRILE	NITRILE	225 (107)
NR	NEOPRENE	NATURAL RUBBER	180 (82)
VV	VITON	VITON	250 (121)

Check-Flex Inlet Flanged Inline Valve Gen5



CF-ILIF-G5-Inlet FLange

PROJECT NOTES:

PROJECT NAME:

CUSTOMER:

SIZE A	SCALE NTS	DRAWING No.	SHEET 1 OF 1
-----------	--------------	-------------	-----------------

EMAIL: info@measurit.com
 PHONE: (IRL) 01 484 7832, (UK) 020 3946 3242
 WWW.MEASURIT.COM

F

U

L

G

5

CF-IL-G5-FU